

SSP 170-800 kV Semi-pantograph disconnector



**HV Switching**

## We know how

Our range of semi-pantograph disconnectors is designed to ensure the best performances and reliability, which are the result of our 60-year old experience.

Over 50,000 disconnectors installed in more than 100 countries worldwide are the guarantee of best-buys.



## The SSP semi-pantograph disconnector

The SSP disconnector is composed of three poles operated simultaneously either by a single operating mechanism and mechanical linkages between the poles, or by one single operating mechanism for each pole.

The semi-pantograph is generally used as a "busbar disconnector", since it allows very reduced phase-to-phase clearances for feeder/transformer bays and stands just beneath the main busbar: no other AIS solution is more compact and efficient.

The reliability of the SSP is ensured by the physical separation of the mechanical and the electrical functions. When short-time current flows through it, the electro-dynamic forces increase the contact pressure of fingers on the fixed contact bar.

The insulating columns used for the SSP comply with the IEC or the ANSI Standards. Special heights and creepage distances are also available upon request.

Like all our models, the SSP complies with the latest international standards (IEC, ANSI), but can also be customised according to customers' particular specifications.

The SSP uses the same technology as that of the OH disconnector (horizontal "knee-type"): both lines distinguish themselves for their simplicity and strength and most components are the same, which allows a better management of spare part stocks and a better training of the assembling workers.

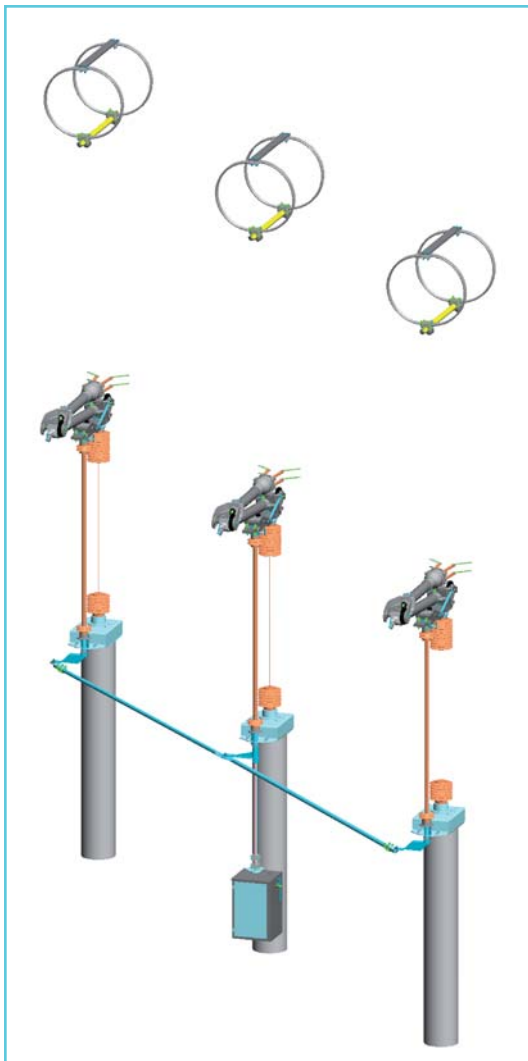

## Earthing switch

Integrated earthing blades are available for mounting on each pole, with the same short-time current withstand capability.

The earthing switch is actuated by the same types of operating mechanisms as the disconnector, either manually or electrically, either single- or 3-pole. It can be electrically and/or mechanically interlocked with the main switch.

## Construction features

The arm of each pole is made of hard-drawn aluminium tubes, with silver-plated copper fingers bolted at the upper end (jaw).

According to the rated voltage, the current path at hinged points is ensured by copper braids or by self-cleaning, maintenance-free rotary contacts, with silver-plated "fingers", individually loaded by stainless steel springs.

The arm is ideally balanced, by a spring housed inside its lower half, to ensure a smooth low energy demanding motion.

The fixed contact consists of a silver-plated copper tube, hung to the upper busbar through flexible aluminium loops ensuring the best alignment, even in case of unexpected motion of the upper busbar. This also allows for an easy adjustment of the position of the fixed contact, whatever the height of the upper busbar. The connector to the upper busbar can be supplied upon request.

All the exposed hardware of the main circuit is made of stainless steel.

The HV terminals are made of robust aluminium-alloy plates.

Where necessary, suitable shields protect the main circuit from the corona effect.

The base-frame is made of hot-dip galvanized steel. The bearings are sealed and guaranteed to ensure maintenance-free operation for the whole life of the equipment.

The whole design and manufacturing process is ruled by ISO 9001 certified procedures, to guarantee a perfect reproducibility of performances from type-testing to the series production.



## Operating principle

The base-frame supports the post insulator on which the moving arm is bolted. The rotating insulating rod (driving insulator), which operates the arm, is directly connected with the operating mechanism.

From the open position, the insulating rod **1** rotates, to transmit the movement to the lower half-arm **2** through a bevel gear and a crank-rod system. The upper half-arm **3** movement is controlled by a rack-pinion system housed inside the elbow. Both half-arms raise together till closing the jaw **4** at the upper end on the fixed contact **5**; the closing of the jaw, controlled by a rod inside the upper half-arm, only occurs in the last phase of the operation, thus giving the disconnector a contact zone suitable for all flexible or rigid busbar systems. After reaching the final closed position, the moving arm is locked by the passing of a dead-point, preventing any accidental opening.

The flat HV terminals are shown in the next page figure; customised terminals are also available upon request.

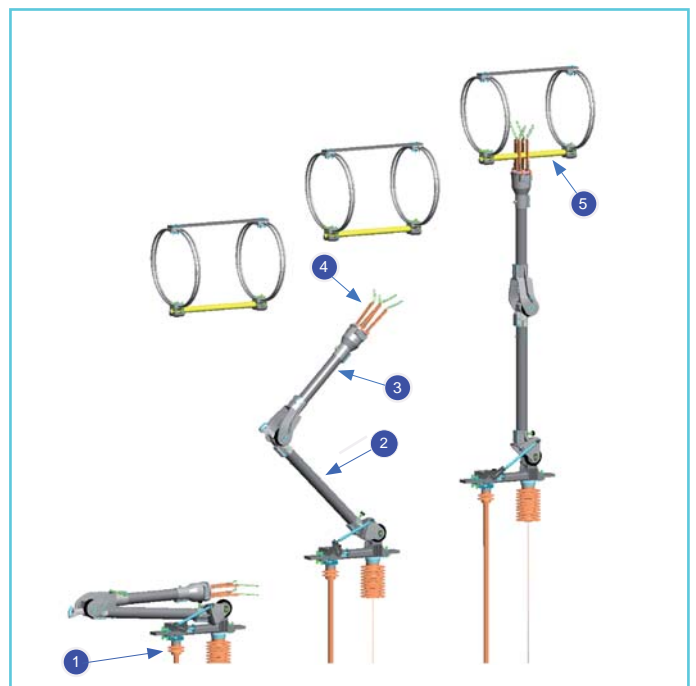

## Ratings and dimensions

The values in the table refer to IEC standards, unless explicit reference to ANSI is made.

Rated voltage		Ur (kV)	170	245	362	420	550	800
Rated power frequency withstand voltage	TE	Ud (kV)	325	460	450	520	620	830
	AID	Ud (kV)	375	530	520	610	800	1150
Rated lightning impulse withstand voltage	TE	Up (kV)	750	1050	1175	1425	1550	2100
	AID	Up (kV)	860	1200	1175 (+205)	1425 (+240)	1550 (+315)	2100 (+455)
Rated switching impulse withstand voltage	TE	Us (kV)	-	-	950	1050	1175	1550
	AID	Us (kV)	-	-	800 (+295)	900 (+345)	900 (+450)	1175(+650)

TE: To Earth AID : Across the Isolating Distance

Rated permanent current	Ir (A)	Up to 4000 A IEC / ANSI
Rated short-time withstand current	Ik (kA)	Up to 63 kA / 3s
Rated peak withstand current	Ip (kA)	Up to 160 kA

Dimensions (mm)	170	245	362	420	550	800
A	300	680	920	920	920	890
B	4235	5640	7350	7825	8750	11850
C	1100	1730	2585	2585	2885	3650
D	670	655	640	640	640	750
E	1925	2525	3130	3560	3860	5204
F (adjustable)	from 800 to 1000					
L	180	180	320	320	320	320
M	230	230	330	330	330	330
K	18 L 40	18 L 40	20 L 40	20 L 40	20 L 40	20 L 40
R	1700	2300	2900	3350	3650	5300

## Reliability and maintenance

Due to lifetime greased or self-lubricated hinges and to self-wiping contacts, the maintenance of SSP metallic parts is ensured by their own motion.

The use of corrosion-free or treated materials for all components ensures an exceptional reliability over many years of service.

The mechanical endurance performance exceeds the IEC standard requirements.

## Optional devices

Upon request, the disconnector can be equipped with a bus-transfer current switching device compliant with IEC 62271-102 (Annex B).

The integrated earthing switch can also be fitted with optional induced current switching devices compliant with IEC 62271-102 (Annex C).

For operation under severe ice conditions (up to 20 mm), ice shields are available for protection of the equipment (where needed).

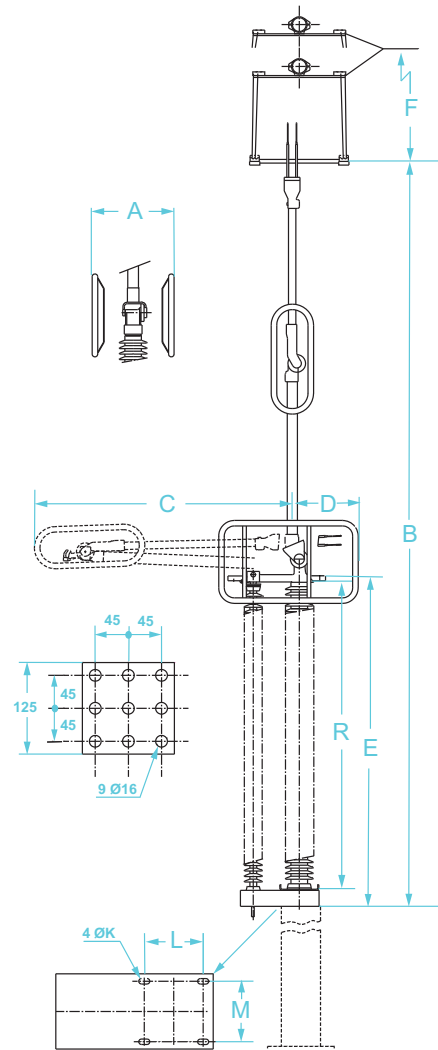

### COELME

Via G. Galilei, 1/2 - 30036 Santa Maria di Sala (VE) - Italia  
Tel.: +39 041 486022 - Fax: +39 041 486909  
E-Mail: contact@coelme-egic.com, www.coelme-egic.com

### EGIC

60b, rue L. et R. Desgrand - 69625 Villeurbanne CEDEX - France  
Tel.: +33 4 72 66 20 70 - Fax: +33 4 72 39 08 65  
E-Mail: contact@coelme-egic.com, www.coelme-egic.com