

SHD 17.5-72.5 kV Vertical-break disconnecter

HV Switching

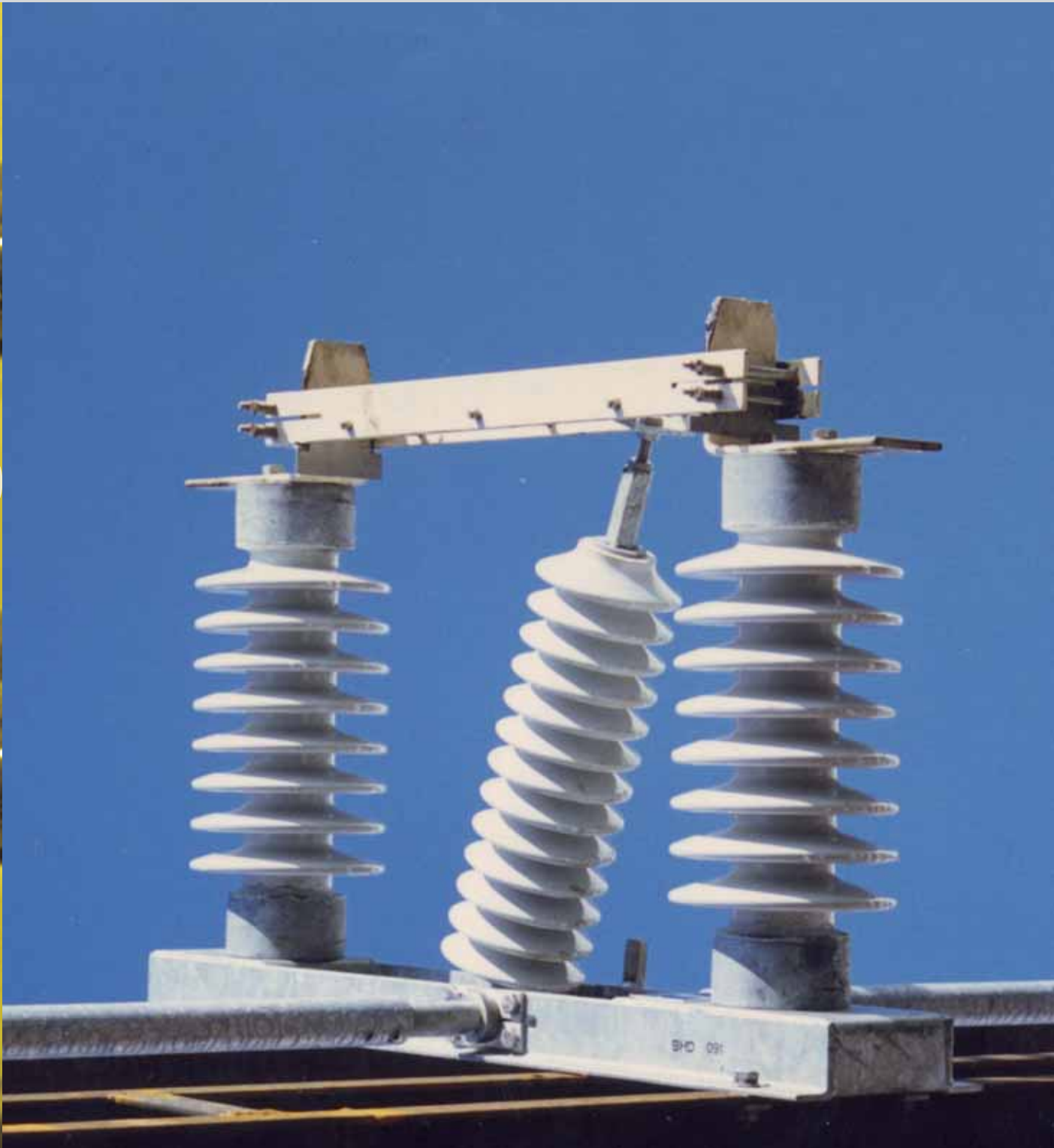

We know how

Our range of vertical-break disconnectors is designed to ensure the best performances and reliability, which are the result of 60-year old experience.

Over 50,000 disconnectors and switchers installed in more than 100 countries worldwide are the guarantee of best-buys.



The SHD vertical-break disconnector

The SHD vertical break disconnector is composed of three poles operated simultaneously either manually or electrically, by a single operating mechanism and mechanical linkages between the poles.

Its versatility and weatherability are considered as a reference: the SHD has been installed in virtually any possible layout throughout the world and under the harshest environmental conditions: from -50°C to $+50^{\circ}\text{C}$, in icy or desert countries and even in the most seismic regions of the planet.

To adapt to various layouts, the poles can be erected traditionally (horizontal) or, wall-mounted and even upside down.

Due to the vertical motion of its main blade, the SHD disconnector features very short clearance between phases, allowing space saving in bay design.

The insulators, directly bolted to the base frame, ensure a good withstand to terminal loads and can comply with either IEC or ANSI standards. Special heights and creepage distances are also available on request.

Like all our models, the SHD complies with the latest international standards (IEC, ANSI), but can also be customised according to customers' particular specifications.

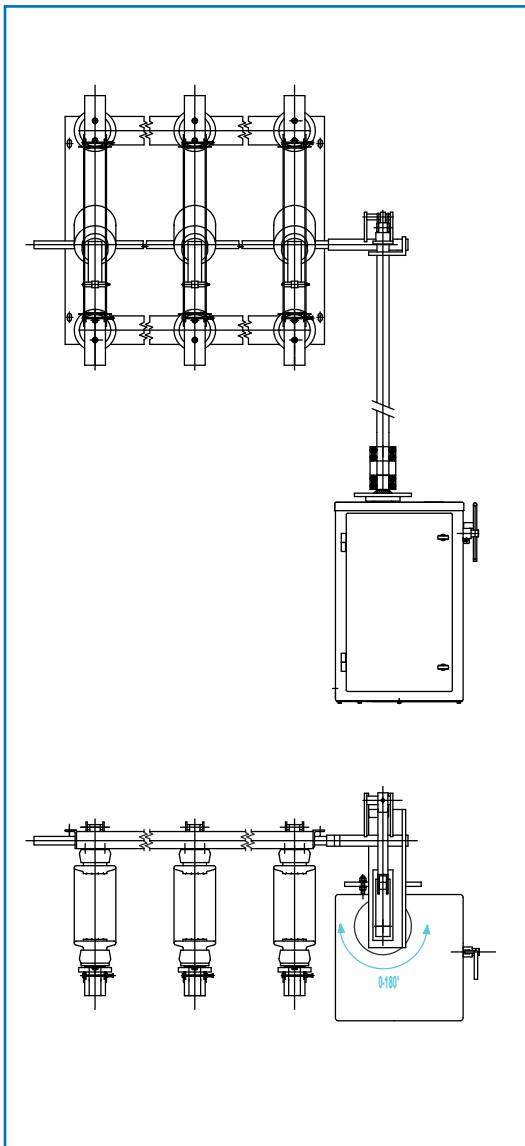

Earthing switch

Integrated earthing switches are available for mounting on each pole, with the same short-time current withstand capability.

The earthing switch is actuated by the same types of operating mechanisms as the disconnector, either manually or electrically, and can be electrically and/or mechanically interlocked with the main switch.

Construction features

The main circuit of each pole consists of a swivel arm and a fixed contact, both made of copper flat bars.

The swivel arm is made of two copper blades, hinge-connected to a bent copper plate, which is bolted to one of the two porcelain post insulators; the fixed contact consists of a bent copper plate, bolted to the other post insulator; the outer ends of copper plates make the HV terminals, whose dimensions are shown in the next page figure (customized terminals are also available upon request). Contact points are silvered; for higher current ratings, or upon request, the silver coating thickness makes the contacts of the "Ag-Ag" type. Contacts are self-cleaning and are designed for withstanding considerable short-circuit stresses.

Under rated service conditions, contact pressure is maintained by stainless steel springs; during a short-circuit, pressure is increased by the fault current path.

The hardware and the hinge of the main circuit, as well as the above mentioned contact springs, are made of stainless steel.

The base consists of a welded frame, made of hot-dip galvanized steel, supporting the three poles (for 72.5 kV disconnector, independent bases could be supplied for each pole); the base-frame is provided with a hot-dip galvanized steel shaft, connected to the arms by means of insulating operating rods.

Each operating rod consists of a cylinder made fibre-glass impregnated with epoxy resin, covered with silicone rubber sheds (in order to ensure a creepage distance not lower than that of post insulators); on request, porcelain operating rods can be supplied.

The whole design and manufacturing process is ruled by ISO 9001 certified procedures, to guarantee a perfect reproducibility of performances from the type-testing to the delivery of series.

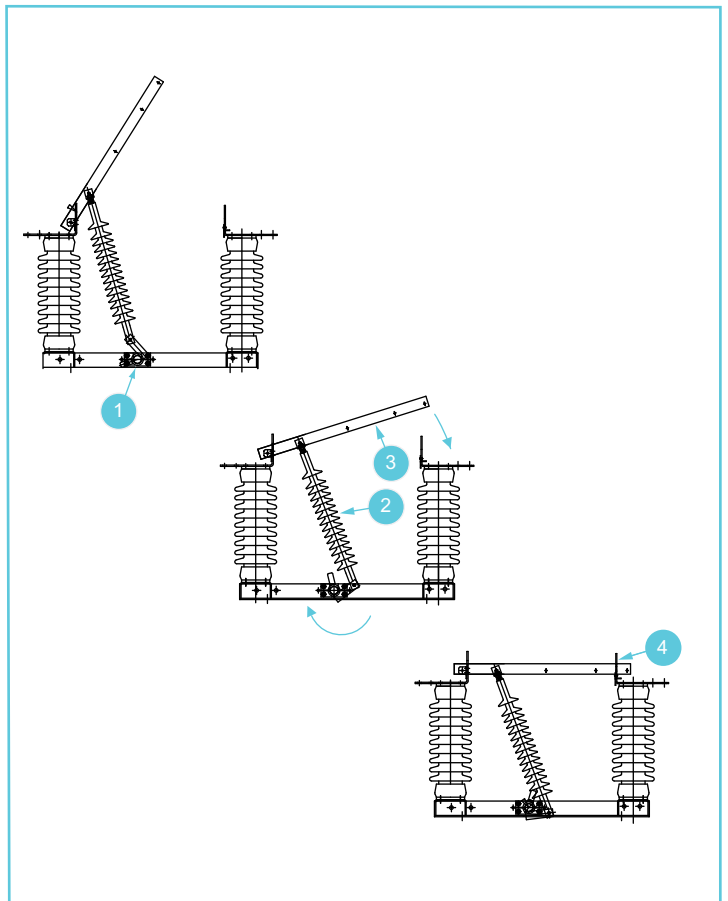

Operating principle

The main circuit of each pole is supported by two post insulators and is hinge-connected to the shaft of the base-frame, by means of an insulating operating rod.

From the open position, the rotation of the base shaft **1**, by means of the operating rod **2**, moves the arm **3**, until its complete insertion in the fixed contact **4**.

The actual angle covered by the arm depends on the rated voltage of the disconnector.

Ratings and dimensions

The values in the table refer to IEC standards, unless explicit reference to ANSI is made.

| Rated voltage | | Ur (kV) | 17.5 | 24 | 36 | 52 | 72.5 |
|---|------|---------|--------------------------------|-------------------------|-------------------------|-------------------------|-------------------------|
| Rated power frequency withstand voltage | TE | Ud (kV) | 38 | 50 | 70 | 95 | 140 |
| | AID | Ud (kV) | 45 | 60 | 80 | 110 | 160 |
| Rated lightning impulse withstand voltage | TE | Up (kV) | 95 (IEC) 110 (ANSI) | 125 (IEC) 150 (ANSI) | 170 (IEC) 200 (ANSI) | 250 (IEC) 250 (ANSI) | 325 (IEC) 350 (ANSI) |
| | AID | Up (kV) | 110 | 145 | 195 | 290 | 375 |
| Rated permanent current | | Ir (A) | Up to 3150 A IEC / 2500 A ANSI | | | | |
| Rated short-time withstand current | | Ik (kA) | Up to 63 kA / 3s | | | | |
| Rated peak withstand current | | Ip (kA) | Up to 160 kA | | | | |
| Dimensions (mm) | | A | 500 | 550 | 700 | 850 | 1000 |
| B | IEC | | 255 | 305 | 445 | 560 | 770 |
| | ANSI | | 254 | 356 | 457 | 559 | 762 |
| C | IEC | | 320 | 370 | 510 | 665 | 875 |
| | ANSI | | 319 | 421 | 523 | 664 | 867 |
| D | | | 135 | 135 | 135 | 135 | 165 |
| E | | | 460 | 520 | 650 | 750 | 900 |
| F | | | 410 | 460 | 610 | 750 | 900 |
| G | | | 90 | 90 | 90 | 120 | 120 |
| H | | | 4 | 4 | 4 | 4 | 6 |
| I | | | 270 | 270 | 300 | 300 | 300 |
| M | | | 35 | 35 | 35 | 60 | 60 |
| O | | | 45 | 45 | 45 | 50 | 50 |

Reliability and maintenance

Due to lifetime greased or self-lubricated hinges and to self-wiping contacts, the maintenance of SHD metallic parts is ensured by their own motion.

The use of corrosion-free or treated materials for all components ensures an exceptional reliability over many years of service.

The mechanical endurance performance exceeds the IEC standard requirements.

Optional devices

Upon request, both disconnecter and earthing switch can be equipped with suitable arcing horns, which prevent damages of main contacts.

For operation under severe ice conditions (up to 20 mm), ice shields are available for protection of the equipment, where needed.

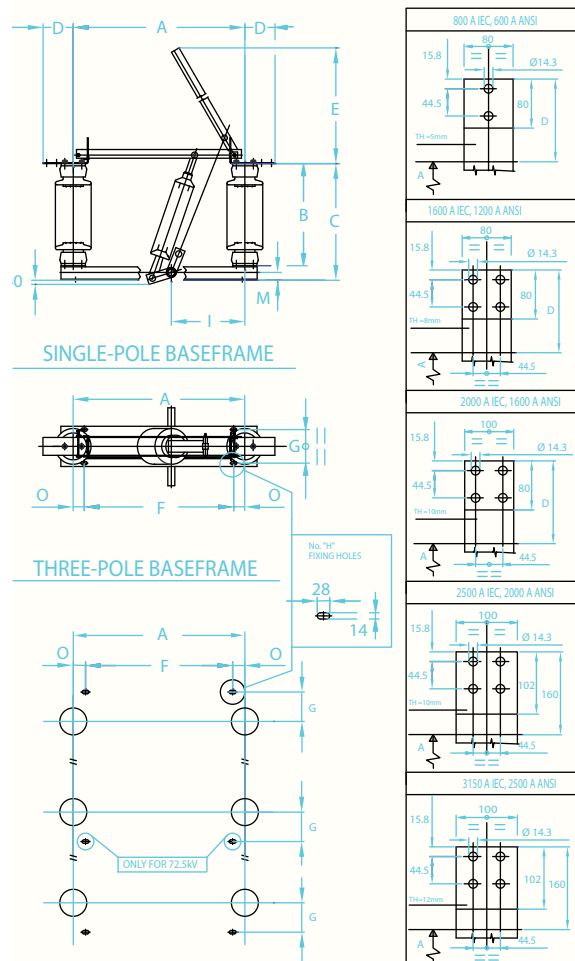

COELME

Via G. Galilei, 1/2 - 30036 Santa Maria di Sala (VE) - Italia
Tel.: +39 041 486022 - Fax: +39 041 486909
E-Mail: contact@coelme-egic.com, www.coelme-egic.com

EGIC

60b, rue L. et R. Desgrand - 69625 Villeurbanne CEDEX - France
Tel.: +33 4 72 66 20 70 - Fax: +33 4 72 39 08 65
E-Mail: contact@coelme-egic.com, www.coelme-egic.com