

Equipment for HVDC substations



HV Switching

We know how

HVDC transmission used to be an ultimate solution to solve specific issues.

In the early 1990s, very few HVDC links were in operation worldwide.

From these initial experiments we developed the capability to design HVDC equipment with the reliability inherited from our 60-year experience and 100,000 Coelme-Egic disconnectors in service around the world.

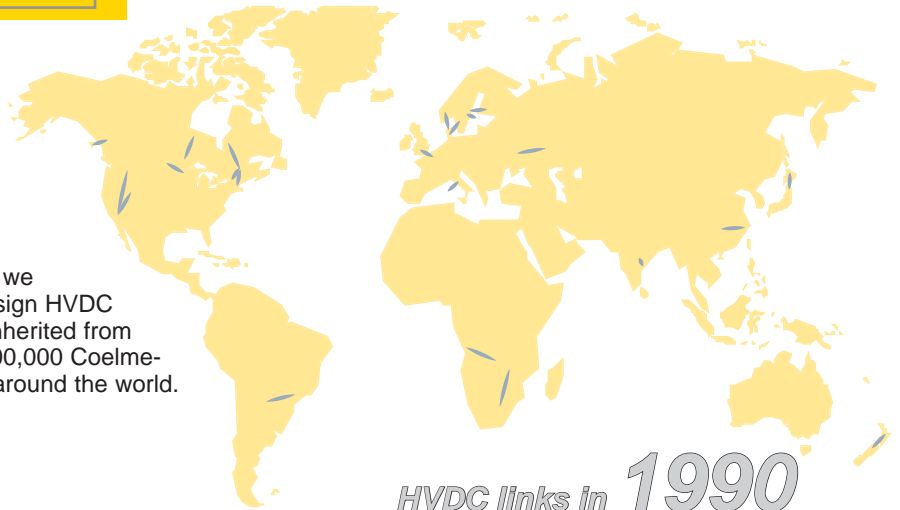

HVDC links in 1990

The HVDC upsurge is just beginning

HVDC links are no longer used only for very specific applications like undersea transmission or asynchronous grids inter-connections.

From an economic point of view they are now efficient for transmission distances of 6-700 km or more, allowing huge power transfer, with less power losses and a better optimisation of conductor size, while offering natural advantages such as avoiding cascading blackouts through the isolation of grid parts.

As power electronics used in HVDC substations is evolving quickly, the switchgear involved in these projects has to comply with new requirements.

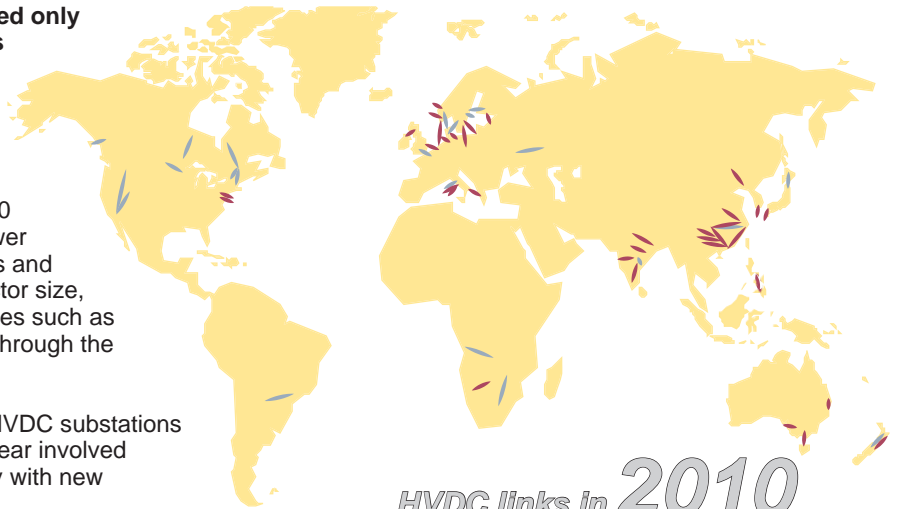

HVDC links in 2010

To protect operators and configure the substation

Being the backbone of a regional transmission system, the HVDC link cannot cope with low-end switchgear which may threaten the reliability of the system.

The main current switching or breaking functions, ensured by circuit-breakers on conventional HVAC networks are guaranteed, for HVDC transmission, by power electronics, which can manage and limit the currents up to fault. However, both disconnecting and earthing switches have maintained a first-class importance, as operational teams still demand to visibly and effectively isolate the circuit from the source during any grid re-configuration or maintenance operation.

Disconnectors and earthing switches are the practical answer to all operational situations.

Thanks to their strategic distribution over the HV scheme, they enable grid management teams to operate the system under all the above-mentioned conditions. Disconnectors and earthing switches feature the necessary versatility and personnel safety.

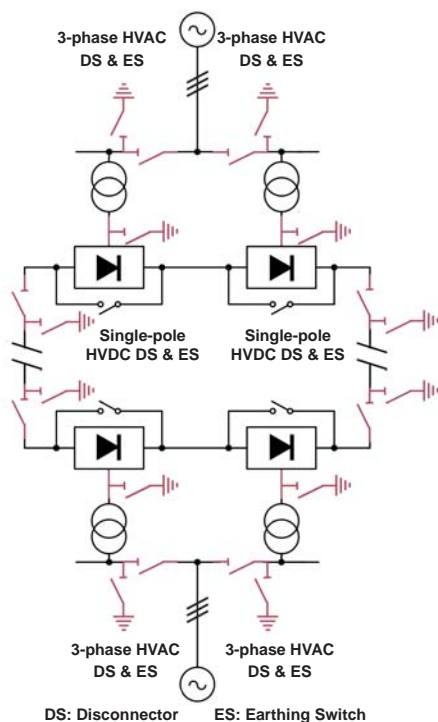

DS: Disconnector ES: Earthing Switch

Valve hall switchgear

The switchgear used in valve hall has to cope with specific constraints.

For maintenance purposes, earthing switches have to be inserted at key nodes of the installation. As the space between transformers and rectifiers has to be minimised, they have to fit into a limited space as well as adapt to the actual layout.

From existing sub-assemblies, validated by extensive testing and successful field experience, Coelme-Egic offers the most effective solutions to earth the transformers bushings on AC side, the DC bus of the poles, or any desired point of the AC or DC circuit. Depending on its function, the earthing switch can be supplied with a support insulator. In this case, the solid insulation creepage distance is defined according to the level of site pollution.

High corona effect is counterbalanced by a gradient minimising design and the use of properly designed corona rings or shields.

Should the disconnecting function be required, the same design philosophy would lead to similarly effective solutions, especially when it comes to switching DC filters, which requires making and breaking on residual currents.

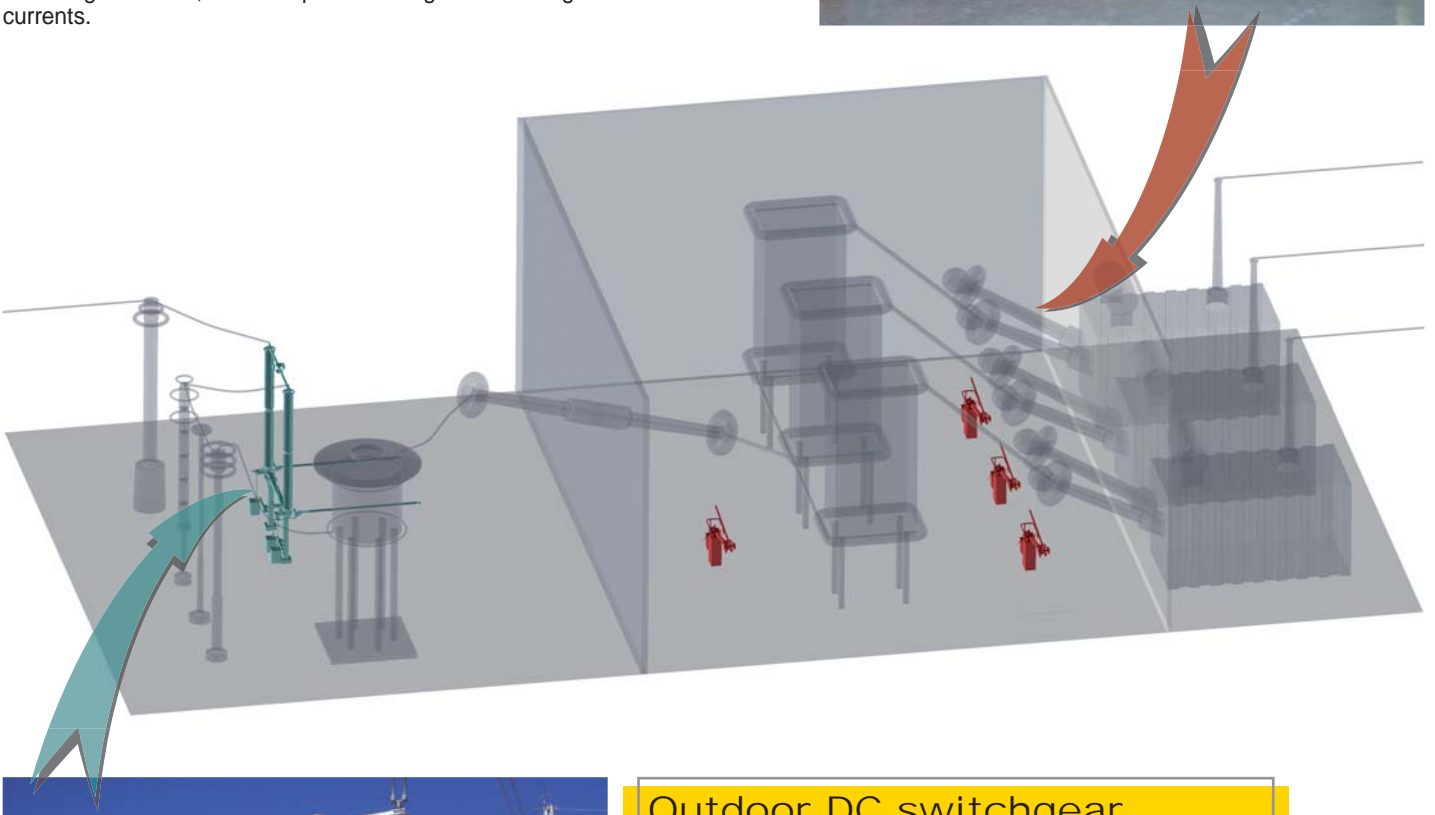
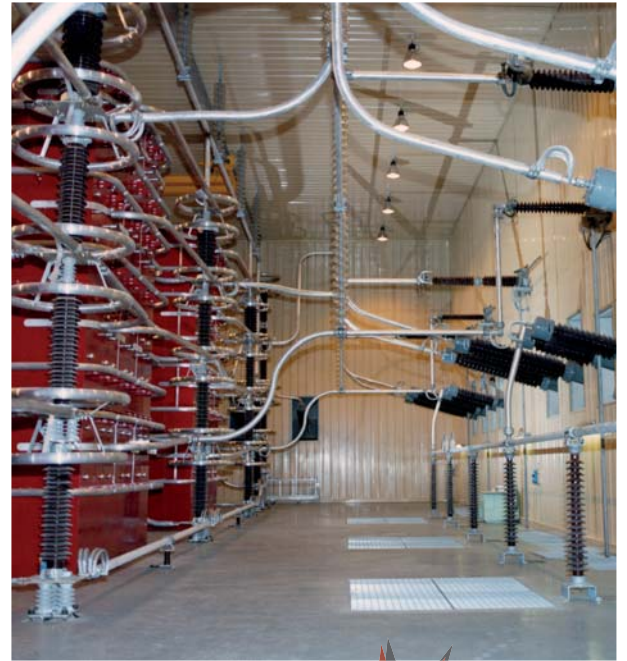

Outdoor DC switchgear

The switchgear used to isolate, earth, and ensure HVDC line maintenance is normally located outdoor, which is why its reliability must never be impaired by weather conditions, pollution or ageing of the substation.

Like AC disconnectors, robustness and reliability over time are the key features of Coelme-Egic HVDC equipment. The design of both live parts and base frames is the result of the integration of multiple parameters, among which are:

- corrosion-free materials or coatings;
- heavy-duty mechanical parts;
- selection of suitable insulator type, with the right shed profile.

Coelme-Egic masters all high-insulator issues.

Since the insulating column is higher, the disconnector design needs to be adapted. The efforts applied to the live part generate high torques applied to the base frame, which is reinforced accordingly. The contact tolerance is adapted to withstand the increased consequences of wind or terminal loads on live part deflection. This prevents any loss of contact which may damage the live part.

Disconnectors

Most disconnector geometries are available for HVDC.

From centre-break to knee-type, we propose the right insulating gap as well as the suitable solid insulation creepage distance. Our equipment is compatible with ground distance ("G") up to more than 7000 mm with no need for modification. Should higher "G" be necessary, specific designs are made.

Single or double integrated earthing switches are available for all HVDC disconnectors.

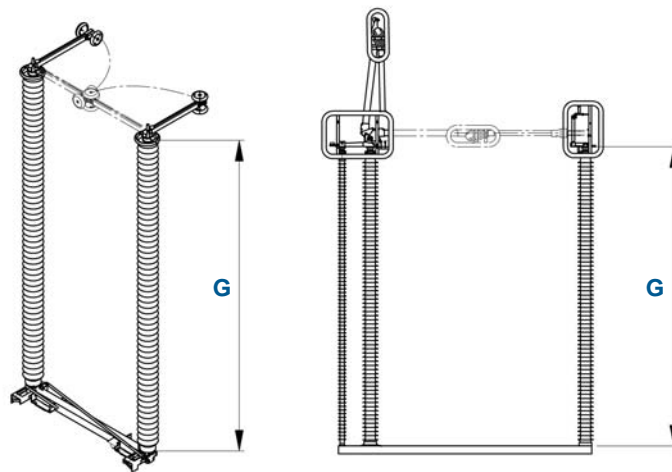

Earthing switches

Earthing switches have to be oversized and comply with exceptional mechanical issues.

Coelme-Egic experience in high voltage enables to design such specific ESs while withstanding the short-circuit constraints. The distance to ground potential ("G") can reach values of 9000 mm and even higher through specific design.

The corona effect must be accurately mastered.

Coelme-Egic is one of the few manufacturers in the world supplying 800 kV equipment regularly, which implies a perfect knowledge of the countermeasures to be taken against corona effect.

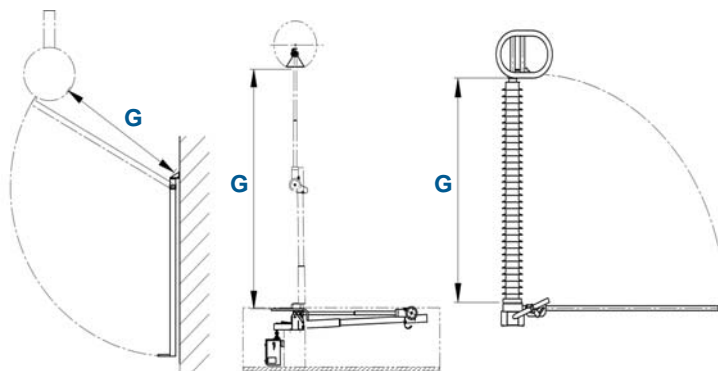

Application engineering

Each HVDC project is different.

For this reason, Coelme-Egic welcomes any specification differing from existing solutions. We have already delivered different types of switchgear, thus solving any issue related to specific contexts or environmental situations.

Coelme-Egic customises the design according to each configuration, using field-proven components.

Our great experience and powerful 3D CADs allow us to design highly customised equipment in close co-operation with clients. Tailored solutions are tested at the most renowned laboratories, such as CESI, KEMA...

Worldwide coverage with first-class partners

Coelme-Egic HVDC disconnectors and earthing switches have been used for many years worldwide under severe environmental conditions, not only in Europe, but also in Africa and South America. We were awarded qualifications by important customers, such as ABB and prestigious end-users like ENEL-TERNA.

Moreover, our constant relationship with first-class partners of Transmission and Distribution enables us to collaborate with them on any project worldwide.

COELME

Via G. Galilei, 1/2 - 30036 Santa Maria di Sala (VE) - Italia
Tel.: +39 041 486022 - Fax: +39 041 486909
E-Mail: contact@coelme-egic.com, www.coelme-egic.com

EGIC

60b, rue L. et R. Desgrand - 69625 Villeurbanne CEDEX - France
Tel.: +33 4 72 66 20 70 - Fax: +33 4 72 39 08 65
E-Mail: contact@coelme-egic.com, www.coelme-egic.com